



ADVANCED POWER  
TECHNOLOGIES

# Electrical House (e-House) Walk-in Switchgear Building



## PwrHouse 03 Outdoor Walk-In & Skid-Mounted Switchgear Solutions Brochure

[www.appt-power.com](http://www.appt-power.com)  
433 N. 36<sup>th</sup> Street  
Lafayette, IN 47905  
(765) 446-2343

**SAFE SMART SERVICEABLE SWITCHGEAR &  
ENGINEERED POWER SYSTEM SOLUTIONS**



ALN: 547 Rev. 01

# Outdoor Walk-in Construction

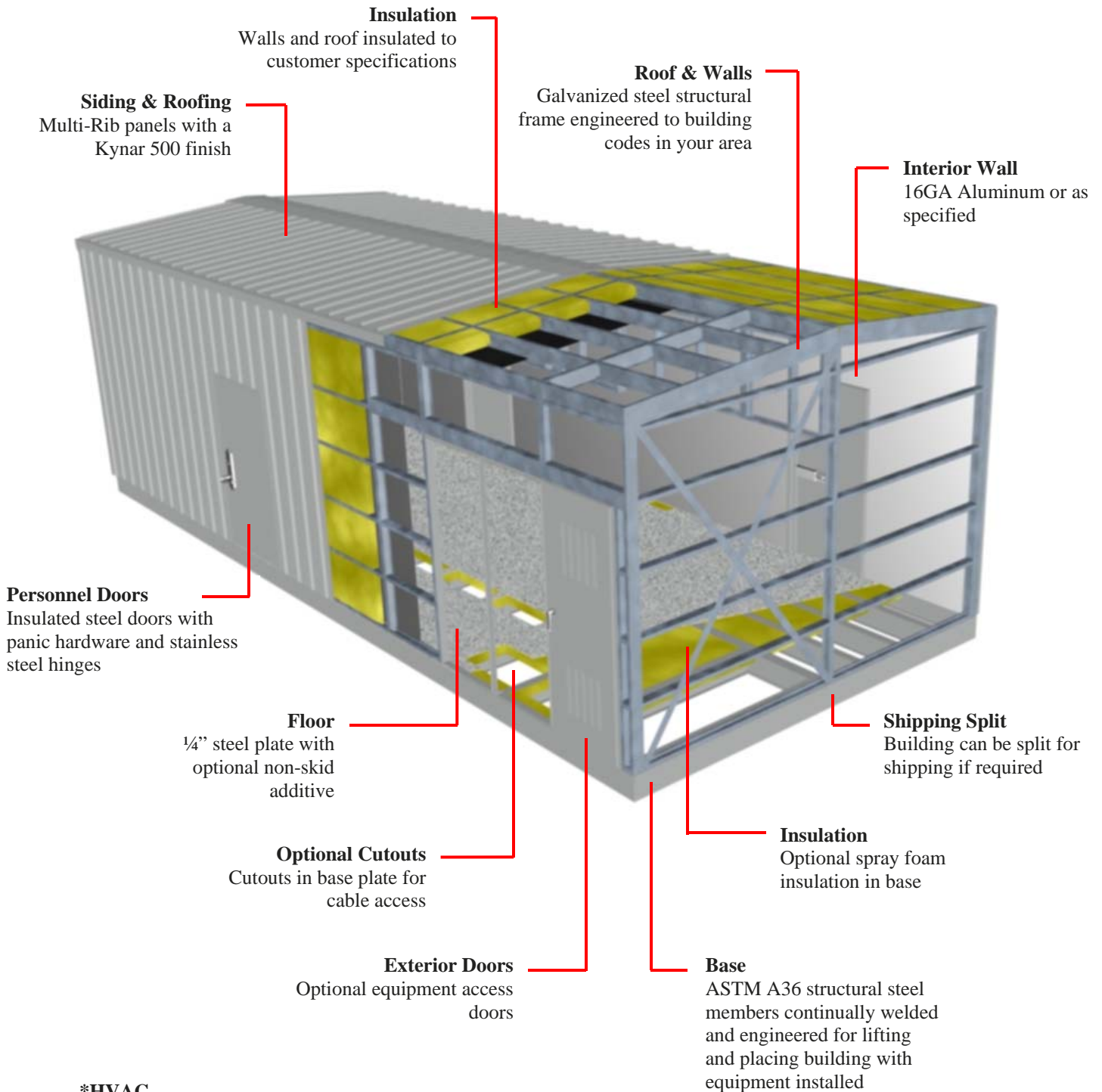

**\*HVAC**  
Optional heating and cooling to meet customer specifications

# Features & Benefits



Figure 1: Outdoor Walk-In Medium Voltage MetalClad / Metal Enclosed e-House

## Low & Medium Voltage Outdoor Walk-In e-Houses

- ⦿ Packaged in a custom equipment building to meet your exact needs
- ⦿ Walk-in switchgear aisle is constructed as one piece of custom building or enclosure to simplify onsite installation
- ⦿ All Equipment inside is factory installed and wired
- ⦿ Available with insulated walls, floor, and ceiling
- ⦿ Optional aluminum diamond plate provides a safe, long lasting, easy to clean floor
- ⦿ Complete with internal lighting (AC and/or DC) and convenience receptacles
- ⦿ Heating and/or cooling units designed for its operating environment
- ⦿ Separate rooms when appropriate for the application (transformer compartment, etc.)
- ⦿ Rugged, durable, weather resistant construction for the worlds harshest environments
- ⦿ Long life, no maintenance aluminum, insulated walls, and ceiling
- ⦿ For operator safety and a finished look and feel, all internal wiring is run in enclosed ducts, or conduit
- ⦿ Utility metering compartments can be integrated in the switchgear
- ⦿ Configurable for a wide range of applications:
  - Automatic and/or manual generator paralleling switchgear
  - AC or DC variable speed motor control
  - Power distribution switchgear
- ⦿ Side, top, or bottom cable entry and exit
  - Power and control quick connect receptacles are available
- ⦿ Optional site control and monitoring:
  - Modbus serial or Ethernet communications
  - APTView SCADA & computer systems
  - Switchgear Master Control

# Features & Benefits



Figure 2: Outdoor Walk-In Low Voltage Utility & Generator Paralleling Switchgear PwrHouse



Figure 3: Outdoor Walk-In Medium Voltage Utility & Generator Paralleling Switchgear PwrHouse

**Year-Round Clean & Safe Work Environment with Optional Climate Controlled Sheltered Aisle**



Figure 4: Inside Aisle of Low Voltage Utility & Generator Paralleling Switchgear PwrHouse



Figure 5: Inside Aisle of Medium Voltage Utility & Generator Paralleling Switchgear PwrHouse

**Keep Operators & Personnel Comfortable & Happy**

# Typical Dimensions & Layout

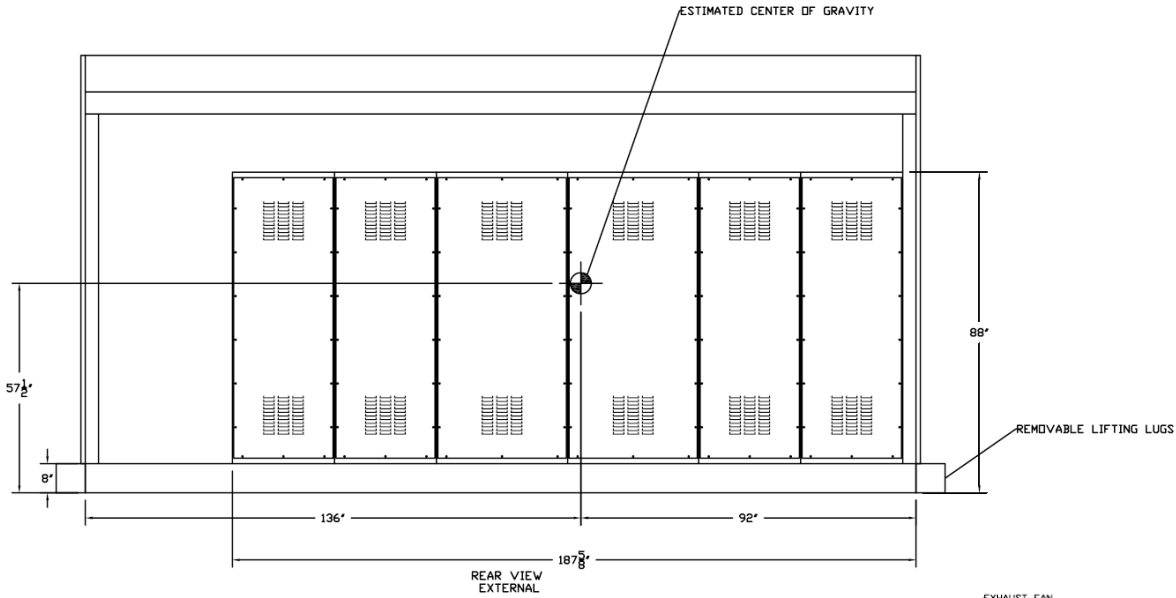

Low Voltage e-House  
 Switchboards  
 Switchgear  
 Motor Control Centers  
 Panels & Power Control

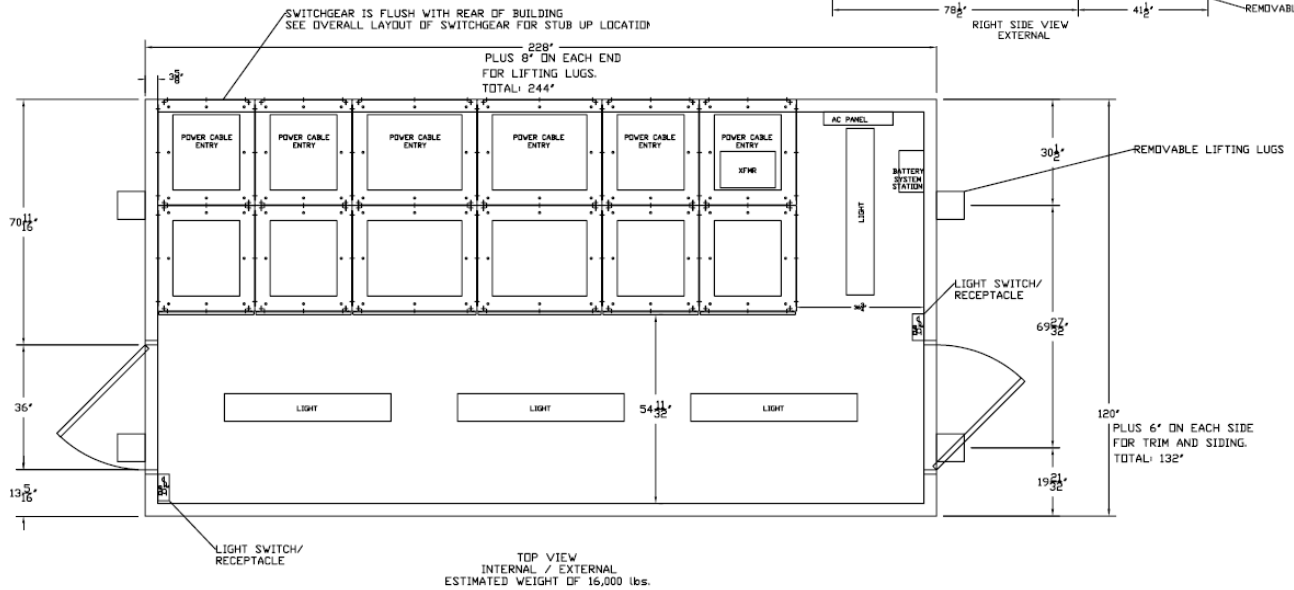
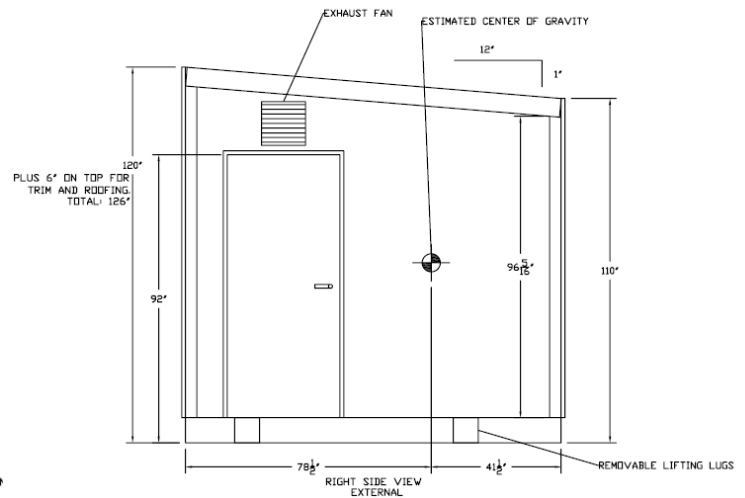

# Typical Dimensions & Layout

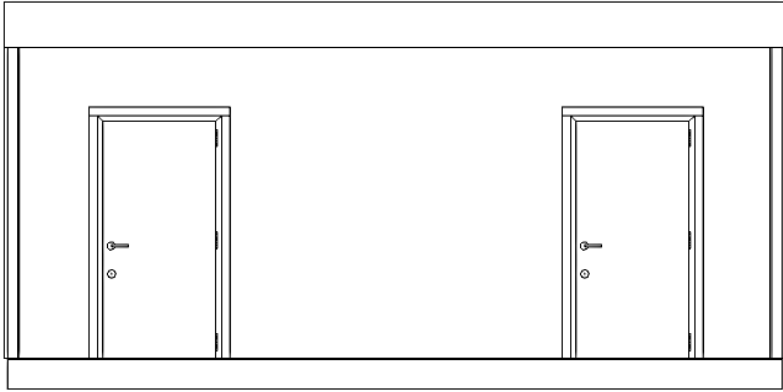

FRONT VIEW

Medium Voltage e-House  
 MetalClad Switchgear  
 Metal Enclosed Switchgear  
 Motor Control Centers  
 Power Centers

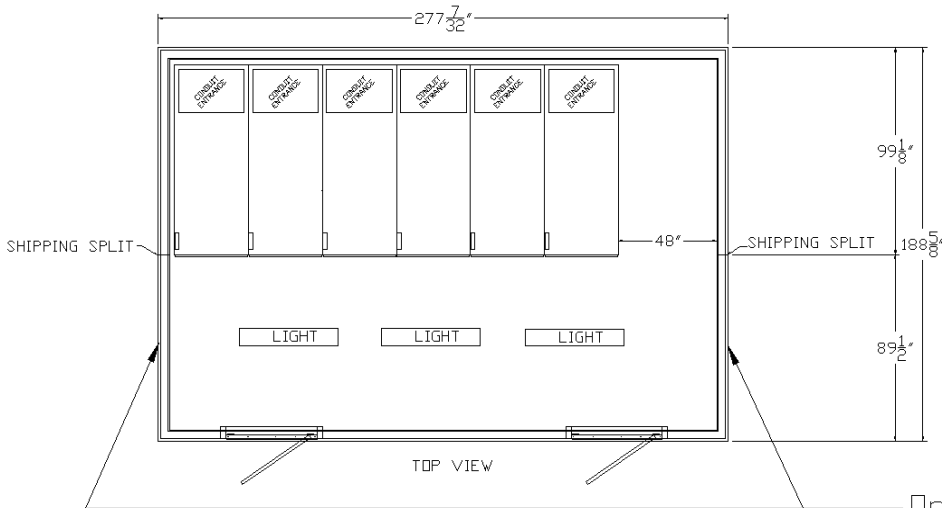

Optional Personnel Door Location

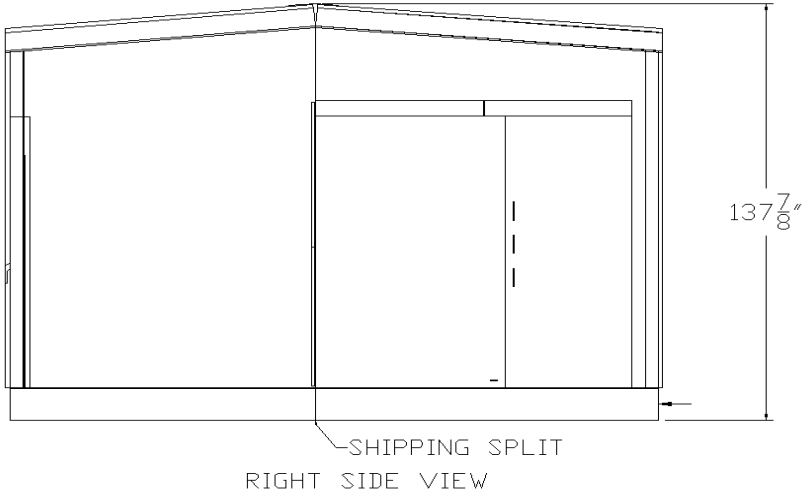



# About Advanced Power Technologies



Advanced Power Technologies (APT) is on the cutting edge of the latest engineered power system smart technologies, as it relates to microgrid & storage management, renewable & conventional energy source deployment, demand peak shaving, and facility back-up and co-generation power systems. Located in the central United States and headquartered in Lafayette, Indiana with solutions development engineers around the country, APT provides domestic and international products and services to industry leading companies from around the world. APT engineers have decades of power system experience from working with some of the largest companies in industry. Over the last two decades, we have produced successful solutions for hundreds of large-scale electric power projects involving utility/generator paralleling, transfer, peak shaving, and distribution. We pride ourselves in providing electrical power systems that are engineered and custom built, utilizing state-of-the-art technologies to fit our customer's exact needs. The core of our business is low & medium voltage engineered power systems for a wide range of indoor & outdoor applications, such as:

- ⦿ Utility(ies) and Generator(s) Paralleling/Transfer/Peak Shaving/Distribution Switchgear
- ⦿ Microgrids, Microgrid Master Control Panels, SCADA systems
- ⦿ Containerized Battery Energy Storage Systems (BESS)
- ⦿ Photovoltaic (PV) Solar Power Collection/Distribution & Renewable Energy Storage Systems
- ⦿ Low & High Resistance Grounding Systems, Grounding Systems for Photovoltaic Effective Grounding
- ⦿ High Efficiency Combined Heat and Power Switchgear & Control Systems (CHP, Co-generation)
- ⦿ Outdoor Walk-In Electrical Houses (E-Houses) & Skid-Mounted Switchgear
- ⦿ Motor Control Centers & Motor Control Switchgear
- ⦿ Automatic & Manual Load Transfer Switchgear
- ⦿ Bypass/Isolation & Power Distribution Circuit Breaker Switchboards
- ⦿ Generator/Loadbank Quick Connection Switchgear, Switchboards, & Tap Boxes
- ⦿ Industrial Control Panels

Please see our product webpages on [www.appt-power.com](http://www.appt-power.com) for product brochures and relevant information. Actual products may look different from images shown on the website and in brochures, based on actual specifications.

APT cares and understands that each power system is different. We will evaluate various solutions in order to develop the best solution for a site. APT focuses on our ability to a combine several traditional pieces of equipment/functionality into as little of a footprint possible. This saves on space, the cost of equipment, cost of installation, and accomplishes the most optimal/state-of-the-art design your facilities. APT's desires to foster and grow a culture of continued open communication with each customer. Let APT be your source to provide fully engineered power system equipment solutions for the full customer facility on time, on or under budget, and in the smallest footprint possible. We are always available to assist customers and engineers representing customers in the development of complex power solutions for all facility types.